

HELITRONIC POWER DIAMOND 400

TWO-IN-ONE, HIGH-PERFORMANCE ROTARY ERODING AND GRINDING MACHINE



HELITRONIC POWER DIAMOND 400

APPLICATION

- Rotary eroding and grinding of rotationally symmetrical tools for a wide range of industries
- For production and/or regrinding
- Fully automated, complete machining in a single clamping cycle
- Materials include PCD, CBN, HSS, carbide, cermet, ceramic

MACHINE

- Low vibration, solid grey cast iron, gantry type construction
- X, Y, Z linear axes with ball-type linear drive
- A, C rotating axes with worm drives or optional torque motors
- Glass scales
- Belt-driven spindle with two HSK50 ends
- FINE PULSE TECHNOLOGY for highest surface quality
- 24" Full HD multitouch display
- FANUC, the global standard for control equipment
- Various loading systems
- Numerous efficiency options

SOFTWARE

- C.O.R.E. OS operating system
- HELITRONIC TOOL STUDIO, CAD/CAM software for design, programming, simulation and production
- HELITRONIC TOOL STUDIO with licence erosion
- Walter Window Mode WWM
- Numerous software options to extend the system's performance and to increase its efficiency

« It is ideal for risk-free entry into the PCD sector, because the Two-in-One design of this machine, which has been successful worldwide for more than 20 years, can be used for only eroding or grinding, or for combining both machining methods without time-consuming reclamping »

YOUR BENEFIT

Eroding of PCD/CBN tools and grinding of HSS/carbide tools, switching as you wish. A variety of loading systems and efficiency options make it possible to configure the machine as needed for today's and tomorrow's applications.



HELITRONIC POWER DIAMOND 400 with the optional electrode/grinding wheel changer (right) and robot loader 25 (left)

C.O.R.E. – CUSTOMER ORIENTED REVOLUTION

C.O.R.E. helps us make your production fit for the digital future.

It's based on a new operating system, C.O.R.E. OS, that equips the machine with intelligence. Thanks to the uniform C.O.R.E. software architecture, exchanging data between UNITED GRINDING machines is easy. The integrated umati API can be used to communicate with third-party systems as well. It also offers access to UNITED GRINDING Digital Solutions™ products directly on the machine. C.O.R.E. not only establishes the technical foundation for this and other IoT and data applications, it also forms the basis of revolutionary yet uniform operation.

What does this mean for you?

- The user-friendly, intuitive, and uniform operation makes work easier for machine setters, machine operators, and maintenance staff
- Standardized data collection and intelligent processing of data creates transparency and supports process optimization
- The uncomplicated and consistent use of modern digital software solutions is guaranteed – directly on the machine
- The technical platform for the use of modern IoT and data applications has been established

C.O.R.E. ELEMENTS

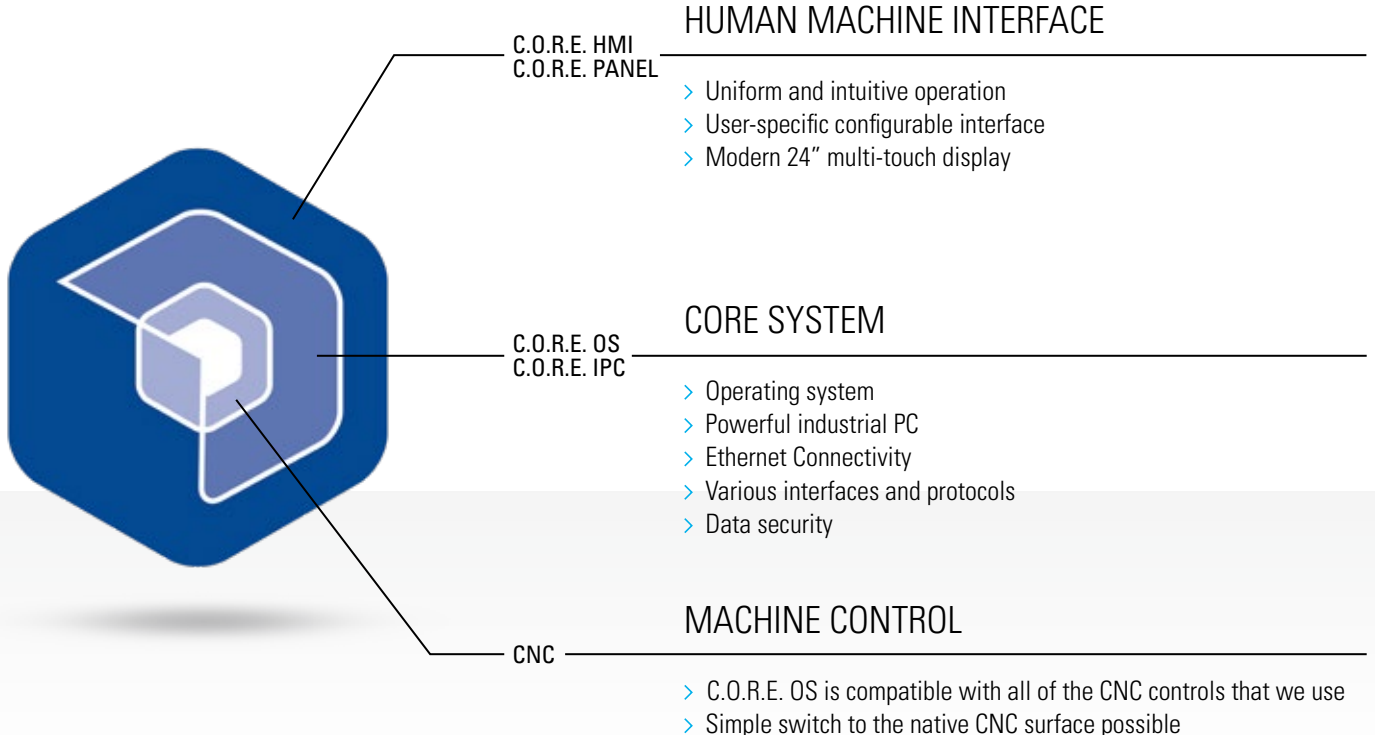

C.O.R.E. PANEL – THE FUTURE OF OPERATION

Intuitive

Thanks to intuitive design with self-explanatory icons, navigation through the machine menu and process steps is quick and easy. Instead of buttons, the user is presented with a modern and clearly arranged multi-touch display.

User-friendly

Each user configures their own user interface individually. This is called up automatically with the RFID chip after logging in. When the user leaves the machine, the panel switches to "Dark Factory Mode." Production progress and the machine state are also clearly visible from

a distance. And thanks to the ergonomic design, the panel can be tilted and individually adjusted easily.

Efficient

The uniform and intuitive operating philosophy reduces training time. The configurable and role-specific interface helps prevent errors and increases the efficiency and quality of programming. Information can be exchanged quickly and in real-time via the front camera and Bluetooth headset. UNITED GRINDING Digital Solutions™ products can be used directly on the panel.

INDUSTRIAL MULTI-TOUCH DISPLAY

INTEGRATED FRONT CAMERA

SELF-EXPLANATORY ICONS

USER-CONFIGURABLE DISPLAY

STANDARDIZED FUNCTION KEYS

ERGONOMIC OVERRIDE SWITCH



Technical Specifications

- 24" Full HD multi-touch display
- 16-position rotary override switch
- Electronic key switch (RFID)
- Integrated front camera
- Bluetooth V4.0 for headset connection
- 2x USB 3.0 ports
- Adjustable tilt



[FURTHER DETAILS](#)

EFFICIENT AND EASY TO USE

With FINE PULSE TECHNOLOGY, HELITRONIC POWER DIAMOND 400 is at the forefront when it comes to quality for PCD tools. It is an economic investment for both the production and resharping of PCD/CBN tools in the diameter range of up to 380 mm.

It is possible to save time by machining complex geometries in a single clamping cycle. The combination of rotary eroding & grinding provides a real step forward in terms of flexibility and quality. Furthermore, thanks to its Two-in-One principle, the HELITRONIC POWER DIAMOND 400 can be used as a grinding machine for the production and resharping of carbide tools. The changeover from PCD to carbide tools is "on the fly", since it is possible to automatically change between PCD and carbide tools and back again.

Example tools (from top left to bottom right):

PCD end mill, PCD reamer, PCD stepped drill bit, rim drill, 2 x PCD multi-step tool, PCD drill, shaped lathe tool, ball nose tool, thread milling drill, drill, corner radius mill, fir tree tool, shaping tool





INNOVATIVE WALTER GRINDING AND ERODING TECHNOLOGY

Belt-driven spindle with two HSK50 spindle ends (standard)

The powerful belt-driven spindle with two spindle ends can be equipped with up to 3 electrodes or 6 grinding wheels and has a peak power of max. 24 kW. In this configuration, both complex and customary tool geometries can be manufactured economically in medium-sized batches (automation option is required). The different electrode/grinding wheel sets are allocated to the relevant spindle along with all data.

High-frequency motor spindle (optional – not shown)

The high-frequency single-ended motor spindle is equipped with a liquid cooling system. Up to 3 electrodes or grinding wheels can be mounted per electrode/grinding wheel holder. The speed is infinitely variable between 0–24,000 rpm; the peak power is 26 kW.

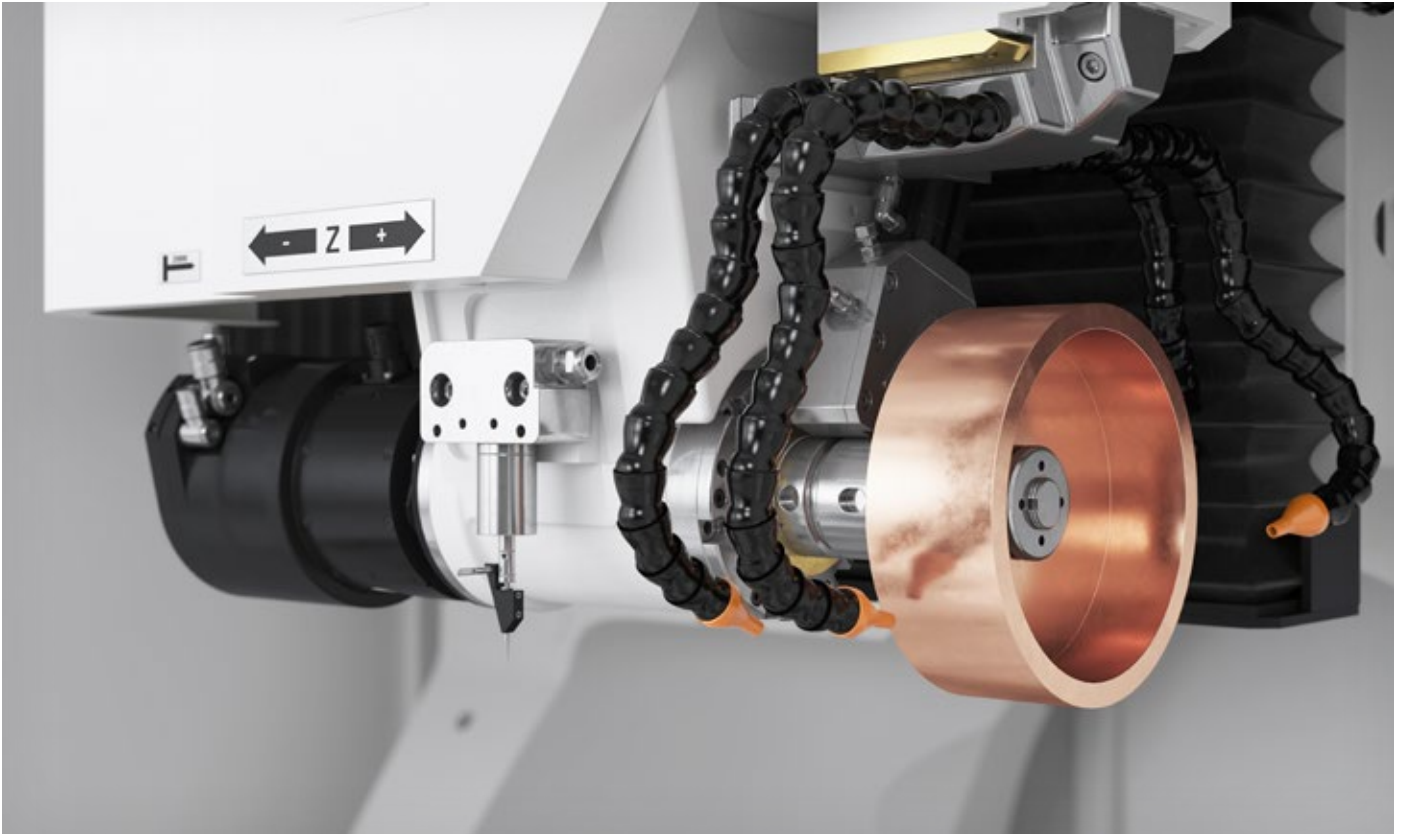

Directly driven motor spindle (option)

The powerful single-ended directly driven motor spindle is equipped with a liquid cooling system. Up to 3 electrodes or grinding wheels can be mounted per electrode/grinding wheel holder. In combination with the electrode/grinding wheel changer, up to 8 holders for 24 electrodes/grinding wheels can be used in the grinding process. The result is the highest levels of efficiency and productivity.

Electrode/grinding wheel changer 4 x or 8 x (options)

Affordable, compact, and flexible too. With a capacity of up to 24 electrode/grinding wheels, it quadruples the grinding wheel capacity of the HELITRONIC POWER DIAMOND 400. The max. grinding wheel diameter is 200 mm. The coolant supply and the grinding set form a single unit. This ensures reliable wheel set replacement and optimum coolant delivery.

ROBOT LOADER AUTOMATION OPTION



Robot loader

The robot improves accessibility to the workpieces and makes special applications possible. Automatic teaching enables short setup times. Depending on the type of workpiece or the workpiece diameter, up to 7,500 workpieces can be loaded using the robot. Maximum workpiece weight 5 kg; maximum workpiece diameter 125 mm.



“Combi” equipment package for robot loaders

Gripper rapid replacement system for handling cylindrical tools and tools with HSK-63 mounting shank. The word “Combi” is an exact description of the contents of this equipment package: Namely the two equipment packages “Cylindrical tools” and “HSK” plus the rapid replacement interface for fast, user-friendly retooling.

Advantages of the “Combi” equipment package

- Rapid replacement sequence thanks to only one cylinder head screw
- Pallets that have already been taught do not need to be taught again when grippers are replaced
- Pneumatics and teaching cable need to be connected only once (installation)
- Retrofitting at existing robots possible (software must be adapted)
- Easy handling
- Ergonomic form

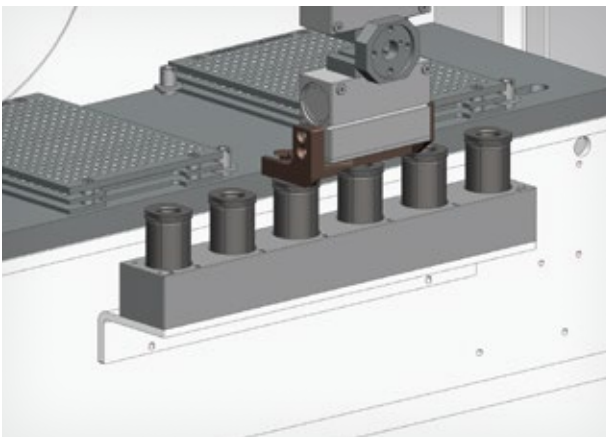

“Multi-Range” equipment package for robot loaders

The Multi-Range equipment package sets new standards in terms of flexibility. Large diameter coverages with a pair of gripper fingers and a collet replacement (Schunk bayonet) are possible with this equipment package.

“HSK” equipment package for robot loaders (not shown)

For handling (automatically loading) up to 72 HSK 63A or HSK 63F tools.

ROBOT LOADER 25 AUTOMATION OPTION

Robot loader 25

For tools in an HSK holder with a total weight of up to 20 kg and a tool diameter of up to 320 mm in combination with the HELITRONIC POWER DIAMOND 400. Thanks to the innovative, recently developed "Process Manager" loader software, "chaotic" loading on up to 7 pallet levels is now possible. An automatic diameter determination is also optionally available and ensures a smooth, automated and flexible production sequence.

Capacity of the available pallets:

- 21 tools, max. diameter 320 mm
- 28 tools, max. diameter 220 mm
- 70 tools, max. diameter 105 mm

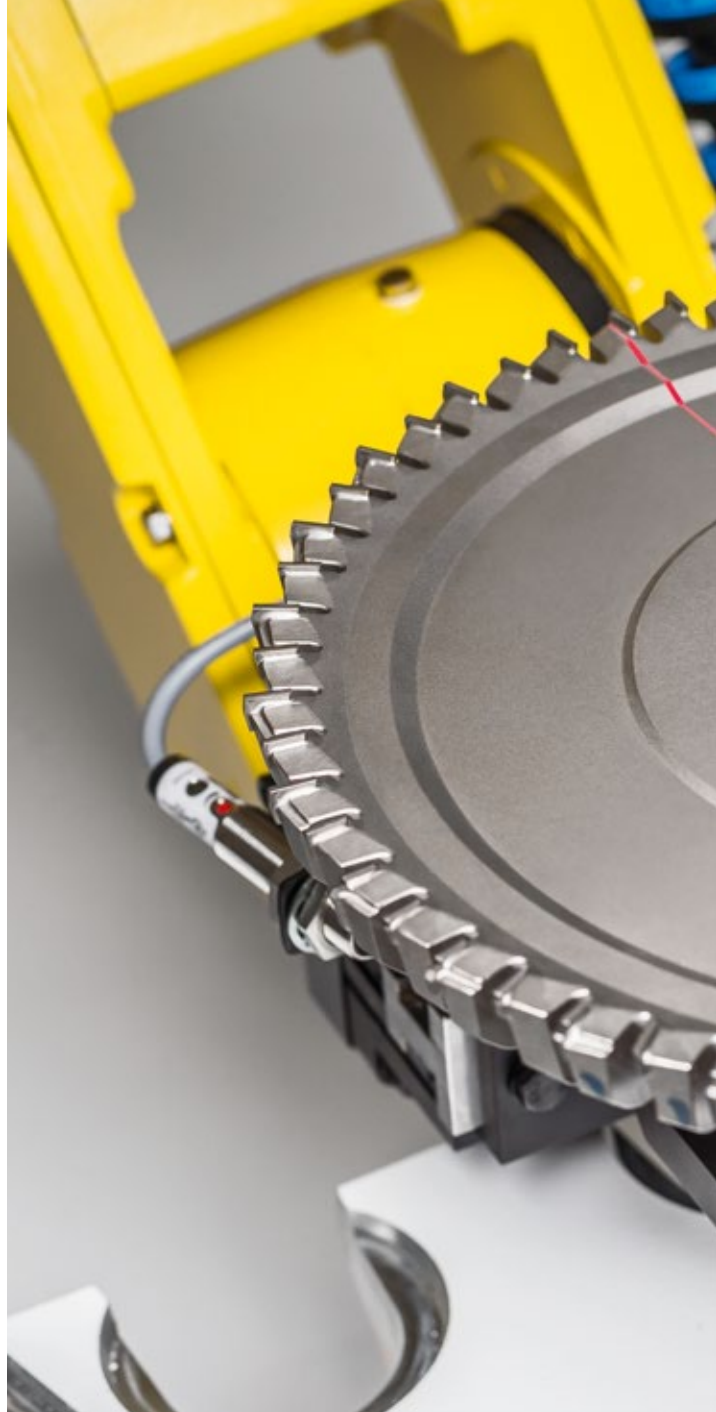

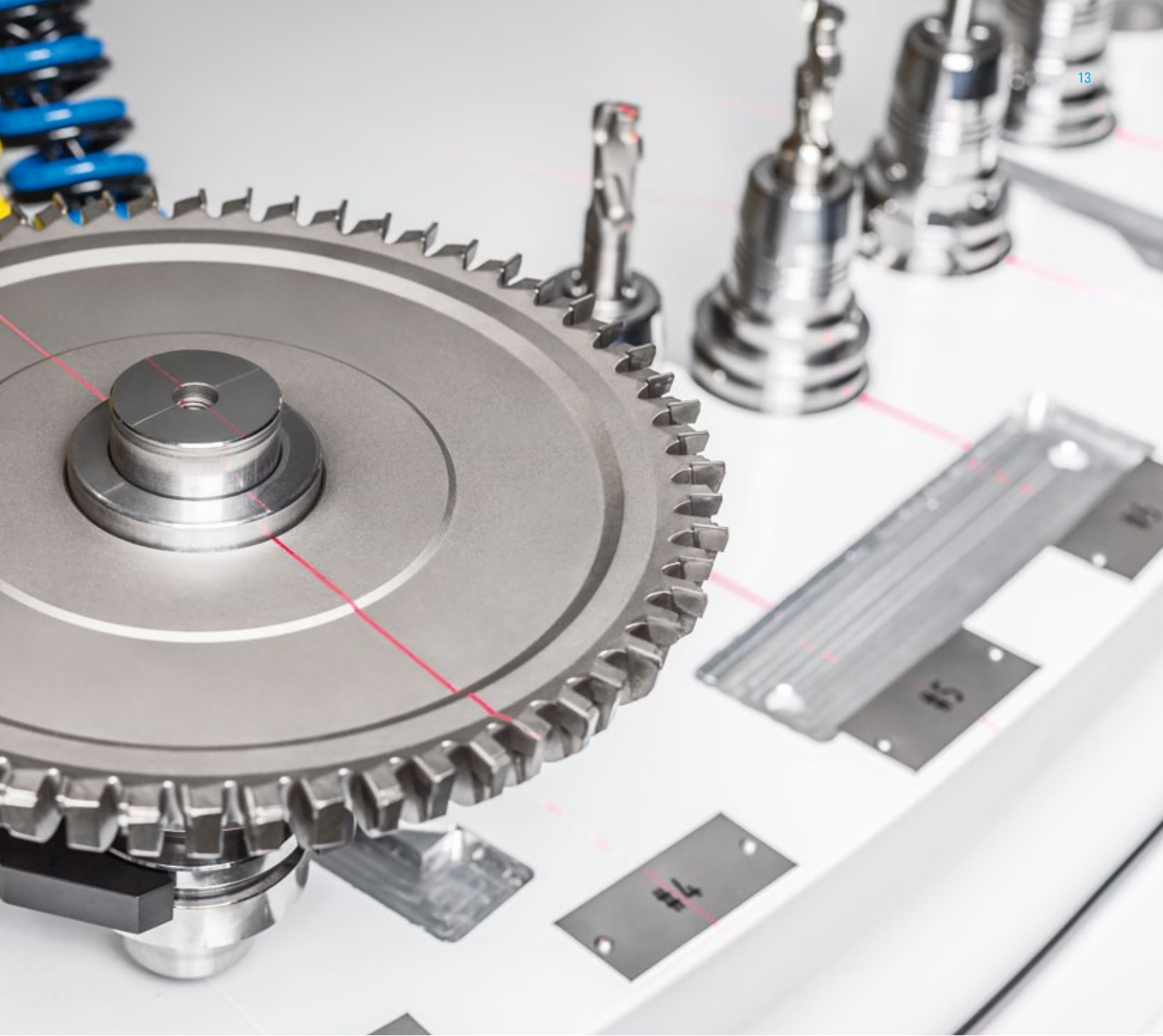

TOP LOADER AUTOMATION OPTION

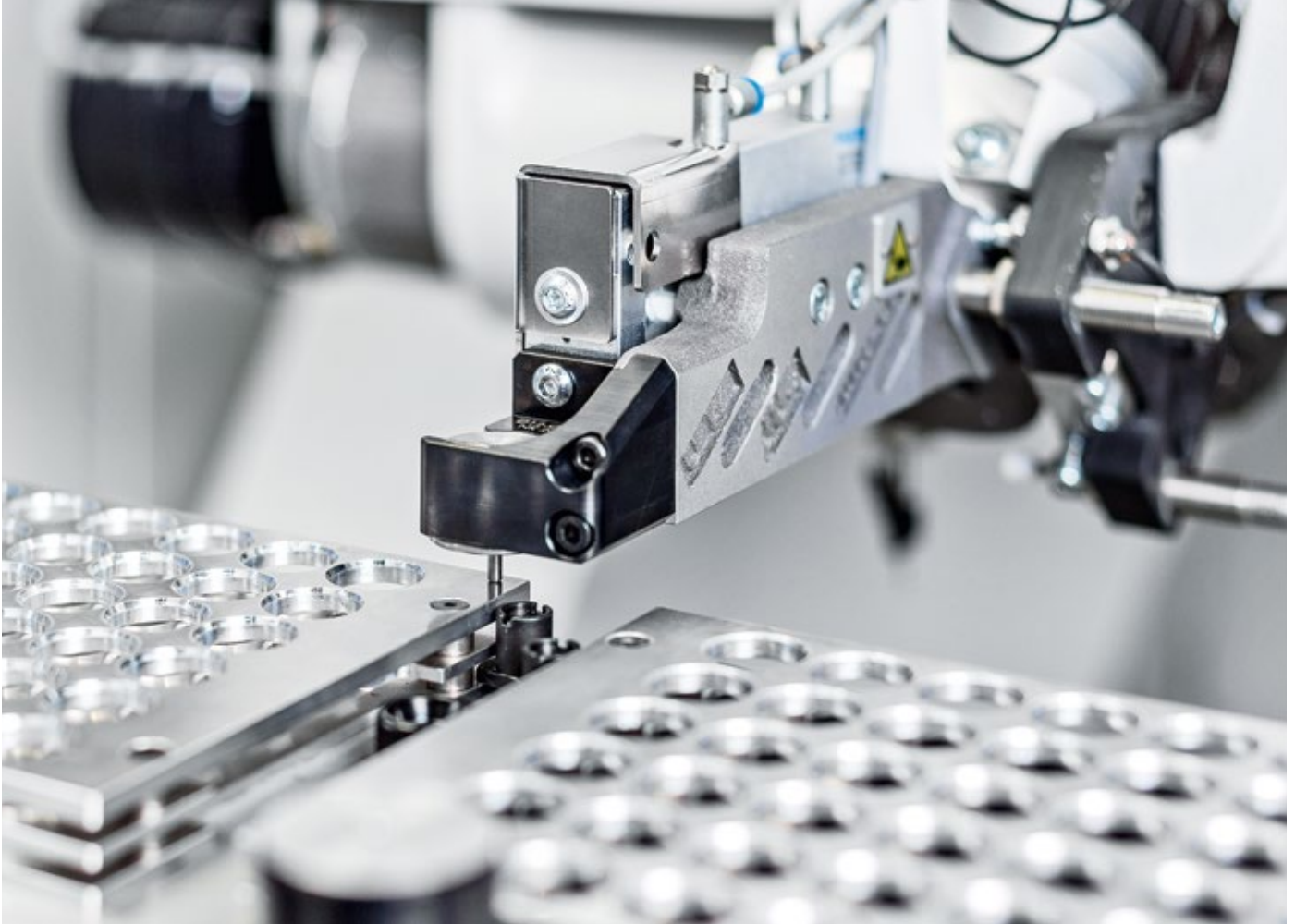

Top loader

This space-saving and inexpensive automation solution is integrated directly into the machine envelope. Automatic teaching enables short setup times. Depending on the tool diameter, the Top loader offers a maximum of 500 places for tools.

Tool capacity, max. (sample diameters):

- 500 tools: diameter 3 mm
- 42 tools: diameter 20 mm
- 20 tools: diameter 32 mm

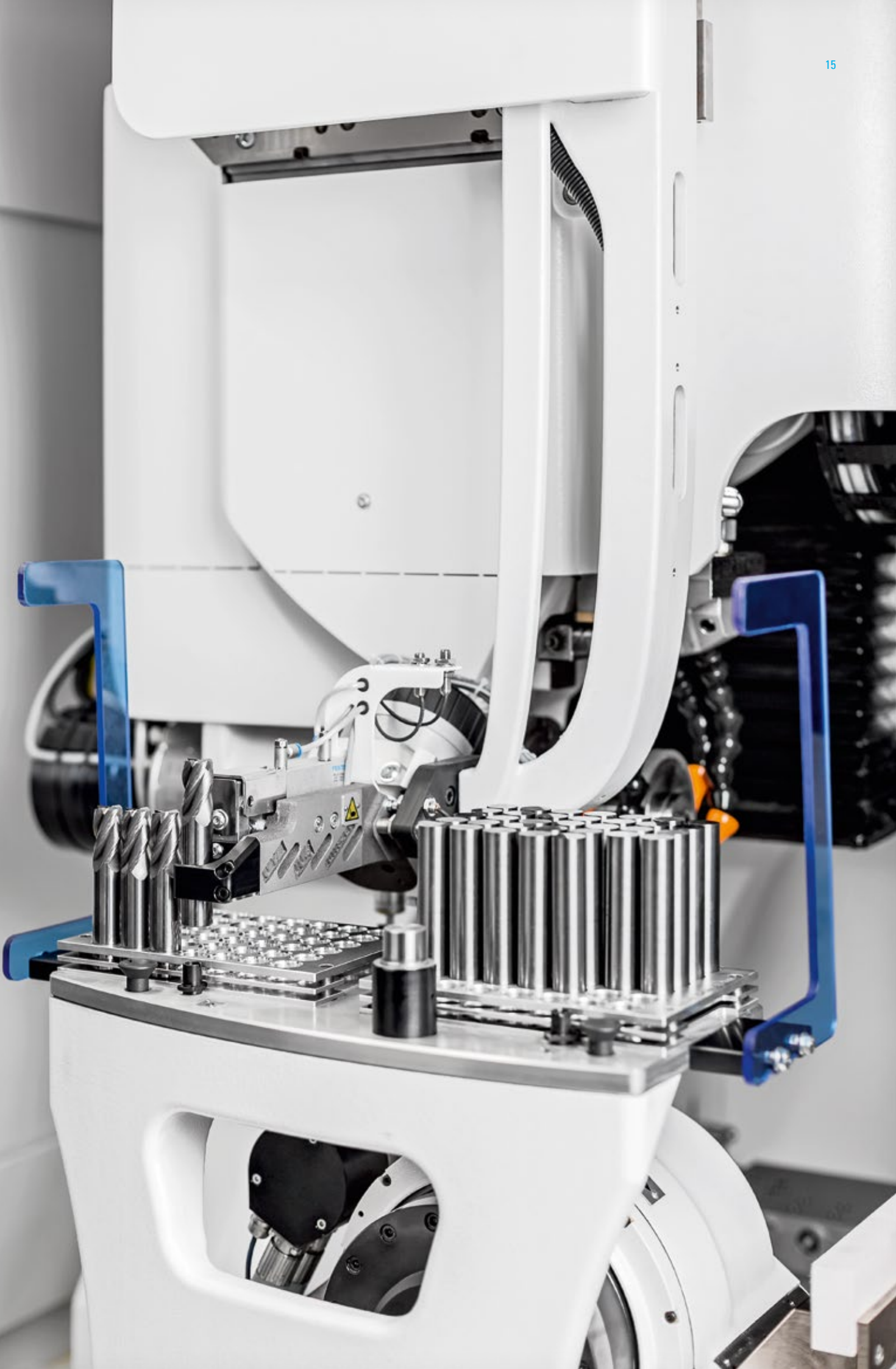

OTHER OPTIONS/ACCESSORIES

The HELITRONIC POWER DIAMOND 400 offers many additional options for optimizing your production – from software solutions to hardware adaptations.

Tool Vision System

Take advantage of the revolutionary benefits of automatic capturing and tool alignment for correct positioning of the tools prior to machining.

Main applications:

- For automated capture of blanks/tools
- With soldered PCD plates on the front
- With sintered PCD veins
- With cooling channels
- And others

Technical details:

- Camera system permanently installed in the robot cell
- Two lenses available
 - > For tool diameter from 1.7 mm to 12 mm
 - > For tool diameter from 12 mm to 32 mm

- Significant time savings with automated processes in comparison to the manual measurement method
- Valuable working time of the employees can be used for other tasks
- Eliminates errors caused by the human factor
- Teaching of new tool geometries is easy and can be done by trained machine operators themselves
- No damage to the tool, thanks to non-contact method
- For tools in the diameter range from 1.7 mm to 32 mm
- Camera system works during off-time

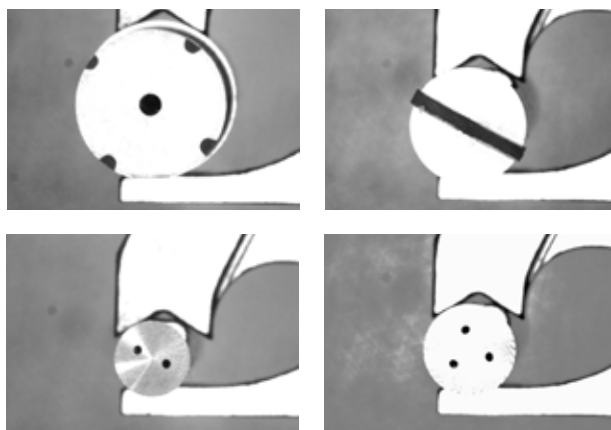
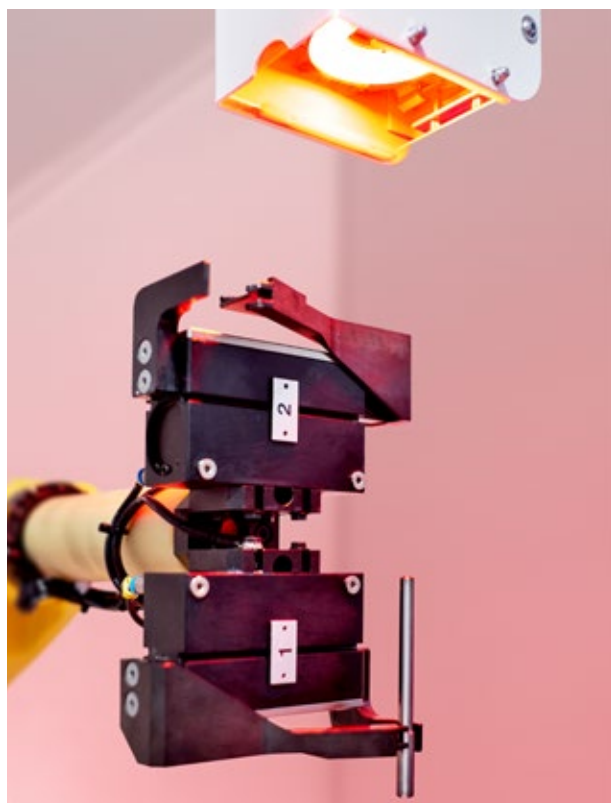



Automatic, electrical Measurement of the machine reference

Now use the advantages of the automatic, electrical measurement of the machine reference in the grinding and eroding machines from WALTER.

- Maximum precision of measurement results through exact positioning of the axes via electrical contact
- Automatic mechanical inspection of the dimensional accuracy of the C axis
- Significant time savings with automatic operation in comparison to the manual measurement method
- Valuable working time of the employees can be used for other tasks
- Eliminates errors caused by the human factor
- Short amortisation time for your investment

Automatic grinding wheel measurement

For even more efficient production. Normally the machine operator corrects the grinding wheel data in the production process manually so that the geometry of the tool can be maintained at its nominal dimension. With the automatic grinding wheel measurement, the wear on the bond of the grinding wheels can be determined automatically via tactile measurement, exactly documented and compensated for. The measurement is carried out during the production process. Diameter and length of the grinding wheel can be measured and compensated for. This means that the operator always has the optimum grinding wheel data at the desired time. Furthermore, the user can monitor the grinding wheel wear and thus influence the production process and optimise it.

The probe for the tactile measurement is fitted on the tool carrier and is mounted in place of the electrical dresser.



OTHER OPTIONS/ACCESSORIES

“HELISET PLUS” accessory

Manual device for measuring complex tools before eroding. Optimizing the machining time by means of up-front measurement – save valuable time in the erosion machine and for tool preparation by carrying out measurement operations at the same time in parallel on the HELISET PLUS.

- Fast, easy measurement
- No programming required
- Eliminates errors caused by the human factor
- Data output via XML
- Touch screen operation
- Outstanding operating concept
- Saves valuable machine hours
- Savings potential up to 30 %



Sharpening stone holder

With the permanently installed sharpening stone holder, WALTER enables the automatic opening of the wheel bond during production. The HELITRONIC TOOL STUDIO software controls the process and enables the operator to open the bond at the appropriate time according to the grinding wheel condition.



Grinding wheel dresser

When it comes to the conditioning/dressing of grinding wheels during the production process, with subsequent software-controlled compensation, the high-performance electrical grinding wheel dresser is the perfect solution.



Integrated Measuring System IMS

With the integrated IMS measurement system, the outside diameter, rake angle and core diameter can be measured using the probe ball without having to unclamp the tool. By setting the tolerances, HELITRONIC TOOL STUDIO can compensate for any deviation of the measured values, e.g. by thermal growth or wheel wear-and-tear, and adjust to the nominal measure and thus prevent scrap. The operator no longer needs to make active adjustments and the dressing cycle of the grinding wheels remains constant. Both increase the efficiency, especially when it comes to large-volume production.

- Determination of the rake angle, the outer diameter and the core diameter for cylindrical tools
- Tactile measurement system to position the tools fully automatically
- Fully automatic thermal profile compensation for the linear axes



Calibration (standard)

Calibration consists of a calibration ball and software. It is used to automatically calibrate the X, Y and Z axes of the machine with a loader. The calibration frequency can be freely chosen in the loader program. Machines without a loading system can be calibrated manually.

Automatic positioning and measurement system "Heli-Probe" (standard)

Heli-Probe records important tool parameters for a perfectly positioned tool in the shortest space of time. This is the best precondition for quick and accurate grinding, quality and productivity.

HELITRONIC TOOL STUDIO WITH EROSION LICENCE

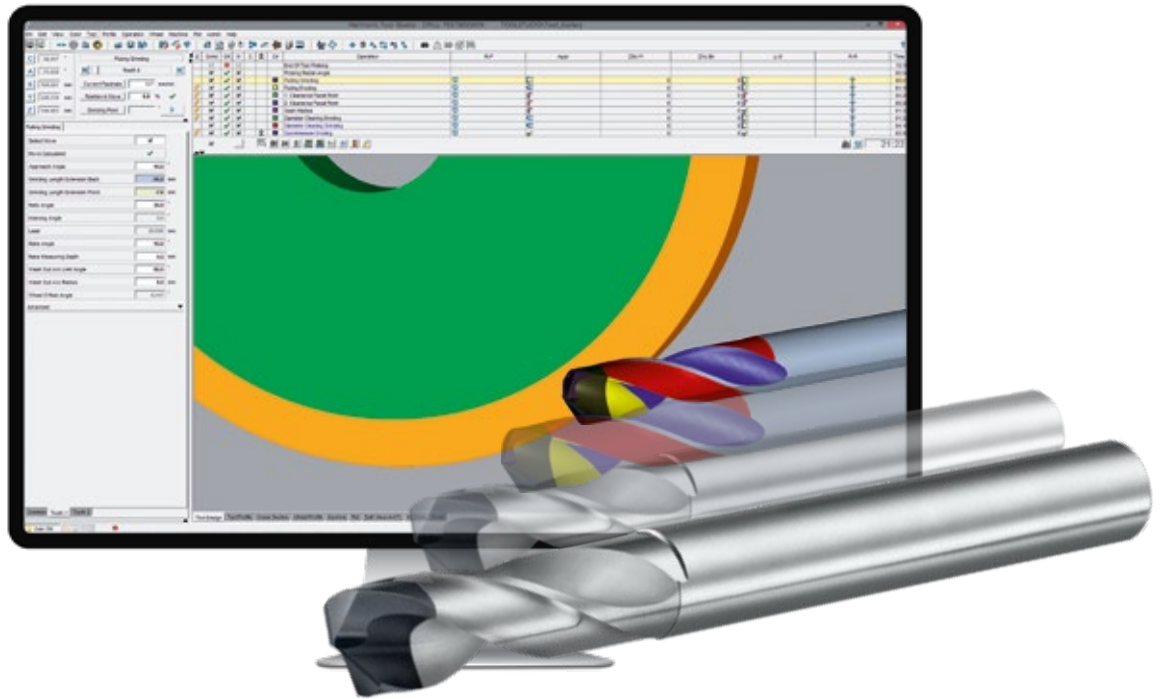

- Time savings through comprehensible and simple operation
- Simulation of grinding and/or eroding operations directly on the machine or at the PC workstation
- High-precision integrated 3D-Live-Simulation – Real-time depiction of all parameter changes
- Click & Edit – simple selection of operations by clicking directly on the simulation model
- Flexible modular system – freely combinable and extendible operations for future further developments

Easy design of PCD tools with HELITRONIC TOOL STUDIO

“What you see is what you grind” – This is the motto for grinding with the HELITRONIC TOOL STUDIO. If one would like to describe the advantages of Licence Erosion in a single sentence, then the best choice would be: “What you can grind, you can also erode”. Thanks to the wizard technology, the operator needs only a few mouse clicks for the production of a perfect PCD tool: Design, programming, simulation and production.

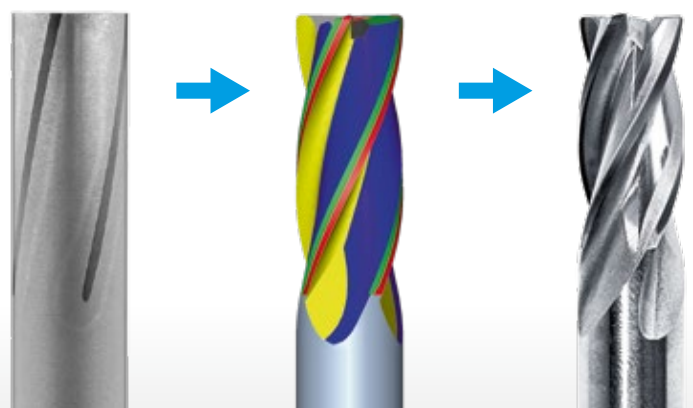

FINE PULSE TECHNOLOGY

TOP SURFACE QUALITY – TOP CUTTING EDGE

FINE PULSE TECHNOLOGY –

Visible improvement with the naked eye

The new "FINE PULSE TECHNOLOGY" sets new standards in terms of the surface quality, cutting edge roughness and process reliability of PCD tools. It is based on a new liquid-cooled generator with an increased pulse frequency. This is now standard equipment in all Two-in-One eroding and grinding machines of WALTER.

The difference to the other tools on the market can even be seen with the naked eye on the most common PCD types with 10 µm grain size. A tool produced with "FINE PULSE TECHNOLOGY" on a WALTER eroding machine shines on its free surface, similar to a polished (ground) tool.

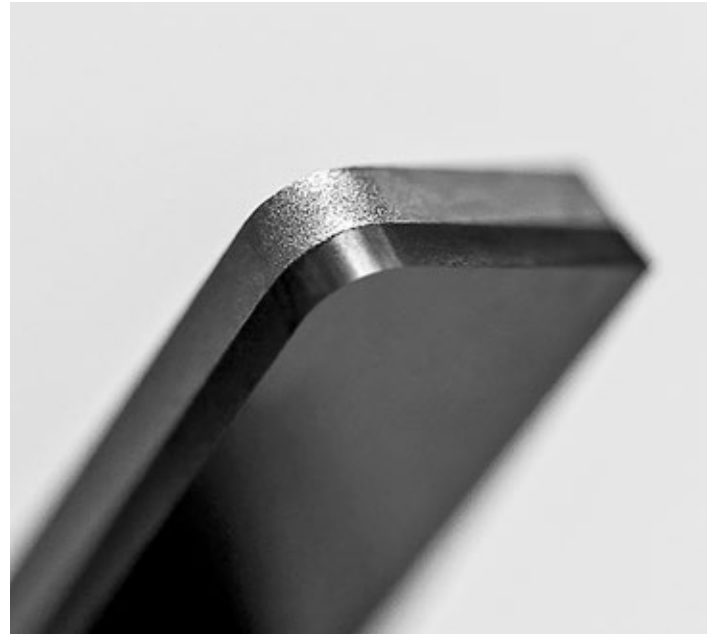

- Greatly improved surface quality
- Perfect blade edge quality
- High process reliability even with difficult-to-erode PCD
- Maximum flexibility with different types of tools
- Short machining times
- Latest state-of-the-art technology
- Optimisation possibilities with all generator codes
- Savings potential in the production chain of PCD tools





CUSTOMER CARE

WE ARE HERE FOR YOU!

WALTER and EWAG deliver systems and solutions worldwide for all areas of tool machining. Our claim is based on ensuring maximum availability of our machines over their entire service life. For this we have thus bundled numerous services in our Customer Care program.

Our products are designed to meet customer demands for as long as possible, they are intended to operate efficiently, reliably, and be available at any time.

From “Start up” through to “Retrofit” – our Customer Care is there for you throughout the working life of your machine. For this reason, you can rely on competent HelpLines worldwide and Service Engineers near you:

- We will provide you with fast, straight-forward support.
- We will help to increase your productivity.
- We work professionally, reliably and transparently.
- We will provide a professional solution to your problems.

UNITED GRINDING DIGITAL SOLUTIONS™

We develop solutions to support you in simplifying processes, boosting your machines’ efficiency and increasing overall productivity under the “UNITED GRINDING Digital Solutions™” brand.

We are continuously expanding our solution portfolio in the key areas of CONNECTIVITY, USABILITY, MONITORING, and PRODUCTIVITY to make your work in the digital age significantly easier.

Find out more about UNITED GRINDING Digital Solutions™ services on our website in the Customer Care section.



Start up
Commissioning
Extension of the guarantee



Qualification
Training
Product support



Prevention
Maintenance
Inspection



Service
Customer service
Customer advice
Helpline



Digital Solutions
Remote Service
Service Monitor
Production Monitor

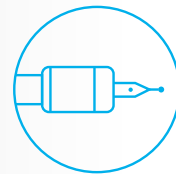

Material
Spare parts
Replacement parts
Accessories



Rebuild
Machine overhauling
Refurbishing of assemblies



Retrofit
Conversions
Retrofitting parts

TECHNICAL DATA, DIMENSIONS

MECHANICAL AXES

X axis	650 mm
Y-axis	350 mm
Z-axis	720 mm
Rapid traverse speed X, Y, Z	max. 15 m/min
C axis	± 200°
A axis	∞
Linear resolution	0.0001 mm
Radial resolution	0.0001°

GRINDING SPINDLE DRIVE

Max. grinding wheel diameter	254 mm
Max. electrode diameter	200 mm
Grinding spindle speed (2 spindle ends)	0–7,000 rpm
Grinding spindle speed (1 spindle end)	0–10,500 rpm

HELITRONIC POWER DIAMOND 400 with belt-driven spindle (standard)

Spindle ends	2
Tool holder	HSK 50
Peak power	24 kW
Spindle Diameter	80 mm

HELITRONIC POWER DIAMOND 400 with motor spindle (option)

Spindle ends	1
Tool holder	HSK 50
Peak power	26 kW

HELITRONIC POWER DIAMOND 400 with high-frequency motor spindle (option)

Spindle ends	1
Tool holder	HSK 50
Peak power	26 kW
Grinding spindle speed	0–24,000 rpm

OTHER

Machine weight	approx. 5,300 kg
Power consumption at 400 V/50 Hz	approx. 25 kVA

TOOL DATA¹⁾

Min. tool diameter	3 mm
Max. tool diameter	315 (380) mm
Max. workpiece length, peripheral grinding ²⁾	520 mm
Max. workpiece length, end face grinding ²⁾	380 mm
Max. workpiece weight	50 kg

OPTIONS

Coolant system

On request – several types are possible

Loading systems

Top loader, Robot loader, Robot loader 25

Others

Motor spindle; high-frequency motor spindle; frequency-controlled pump 80–120 l/min at 7–20 bar; torque motor for A axis 750 rpm; torque motor for C axis; automation upper plate; software; automatic grinding wheel measurement; automatic electrical measurement of the machine reference; manual device for measuring complex tools before eroding; etc.

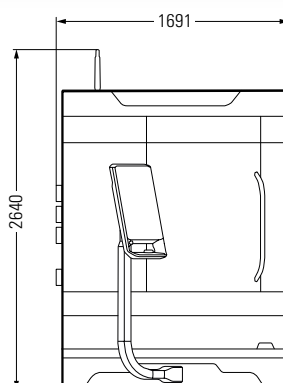
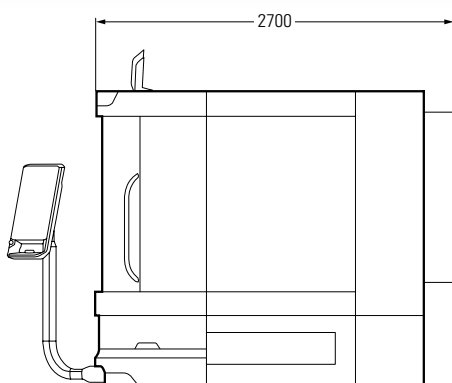

HELITRONIC POWER DIAMOND 400

Dimensions in mm. Options, accessories or open doors can increase the dimensions of the machine. Subject to modifications due to technical progress and errors. No guarantee is provided for this information.

1 The maximum tool dimensions depend on the type of tool and its geometry, as well as the type of machining.

2 From theoretical taper diameter of the workpiece holder.

CREATING TOOL PERFORMANCE

We are a global leader among market-oriented technology and service companies, and a system and solution partner for all areas of tool machining. Our range of services is the basis for innovative machining solutions for practically all tool types and materials typical for the market with a high degree of added value in terms of quality, precision, durability and productivity.



GRINDING

Grinding of rotation-symmetrical tools and workpieces, as well as indexable inserts

Machines	Use Materials	Tool dimensions ¹⁾ max. length ²⁾ / diameter
HELITRONIC ESSENTIAL	P R HSS TC C/C CBN	255 mm / Ø 1 – 100 mm
HELITRONIC MINI POWER	P R HSS TC C/C CBN	255 mm / Ø 1 – 100 mm
HELITRONIC MINI AUTOMATION	P R HSS TC C/C CBN	255 mm / Ø 1 – 100 mm
HELITRONIC RAPTOR	P R HSS TC C/C CBN	280 mm / Ø 3 – 320 mm
HELITRONIC POWER 400	P R HSS TC C/C CBN	520 mm / Ø 3 – 315 mm
HELITRONIC VISION 400 L	P R HSS TC C/C CBN	420 mm / Ø 3 – 315 mm
HELITRONIC VISION 700 L	P R HSS TC C/C CBN	700 mm / Ø 3 – 200 mm
HELITRONIC MICRO	P HSS TC C/C CBN R HSS TC C/C CBN	220 mm / Ø 0.1 – 12.7 mm 220 mm / Ø 3 – 12.7 mm
COMPACT LINE	P R HSS TC C/C CBN PCD	Indexable insert ¹⁾ Inscribed circle/ circumscribed circle Ø 3 mm / Ø 50 mm



LASER

Laser machining of indexable inserts and/or rotation-symmetrical tools

Machines	Use Materials	Tool dimensions ¹⁾ max. length ²⁾ / diameter
LASER LINE ULTRA	P R TC C/C CBN PCD CVD-D MCD/ND	250 mm / Ø 0.1 – 200 mm
LASER LINE PRECISION	P R CBN PCD CVD-D MCD/ND	250 mm / Ø 0.1 – 200 mm
Machines	Use Materials	Indexable insert ¹⁾ Inscribed circle/ circumscribed circle
LASER LINE ULTRA	P R TC C/C CBN PCD CVD-D MCD/ND	Ø 3 mm / Ø 50 mm
LASER LINE PRECISION	P R CBN PCD CVD-D MCD/ND	Ø 3 mm / Ø 50 mm



EROSION

Eroding and grinding of rotation-symmetrical tools

Machines	Use Materials	Tool dimensions ¹⁾ max. length ²⁾ / diameter
HELITRONIC DIAMOND EVOLUTION	P R HSS TC C/C CBN PCD	185/255 mm / Ø 1 – 165 mm
HELITRONIC RAPTOR DIAMOND	P R HSS TC C/C CBN PCD	270 mm / Ø 3 – 400 mm
HELITRONIC POWER DIAMOND 400	P R HSS TC C/C CBN PCD	520 mm / Ø 3 – 380 mm
HELITRONIC VISION DIAMOND 400 L	P R HSS TC C/C CBN PCD	420 mm / Ø 3 – 315 mm



MEASURING

Contact-free measurement of tools, workpieces and grinding wheels

Machines	Use	E1-value	Tool dimensions ¹⁾ max. length ²⁾ / diameter
HELICHECK ADVANCED	M	(1.8 + L/300) µm	420 mm / Ø 1 – 320 mm
HELICHECK PRO	M	(1.2 resp. 1.4 + L/300) µm	300 mm / Ø 1 – 200 mm
HELICHECK PRO LONG	M	(1.2 resp. 1.4 + L/300) µm	730 mm / Ø 1 – 200 mm
HELICHECK PLUS	M	(1.2 resp. 1.4 + L/300) µm	300 mm / Ø 0.1 – 200 mm
HELICHECK PLUS LONG	M	(1.2 resp. 1.4 + L/300) µm	730 mm / Ø 0.1 – 200 mm
HELICHECK 3D	M	(1.8 + L/300) µm	420 mm / Ø 3 – 80 mm



SOFTWARE

The intelligence of tool machining and measuring for production and regrinding



CUSTOMER CARE

Comprehensive range of services

1 The maximum tool dimensions depend on the type of tool and its geometry, as well as the type of machining.

2 From theoretical taper diameter of the workpiece holder.

Use: P Production R Regrinding M Measuring

Materials: HSS High speed steel TC Tungsten carbide C/C Cermet/ceramics CBN Cubic boron nitride PCD Polycrystalline diamond

CVD-D Chemical vapour deposition MCD/ND Monocrystalline diamond/natural diamond

WALTER MASCHINENBAU GMBH

WALTER has produced tool grinding machines since 1953. Today, our product range is supplemented by tool eroding machines and fully automated CNC measuring machines of the HELICHECK series for contactless complete measurement of tools and production parts.

Walter Maschinenbau GmbH is a company of the UNITED GRINDING Group. Together with EWAG, we consider ourselves to be a supplier of systems and solutions for the complete machining of tools and can offer a wide range of products, including grinding, eroding, laser machining, measurement and software.

Our customer focus and our global sales and service network of company-owned locations and employees has been appreciated by our customers for decades.



Grinding



Eroding



Laser



Measuring



Software



Customer Care



ABOUT US

UNITED GRINDING GROUP

UNITED GRINDING Group is one of the world's leading manufacturers of precision machines for grinding, eroding, laser, measuring and combination machining. With around 2,500 employees at more than 20 production, service and sales sites, the Group is organized in a customer-oriented and efficient way.

With its brands MÄGERLE, BLOHM, JUNG, STUDER, SCHAUDT, MIKROSA, WALTER, and EWAG as well as competence centers in America and Asia UNITED GRINDING offers an ample range of application expertise, an extensive product portfolio and an array of services for surface and profile grinding, cylindrical grinding and tool machining. In addition, a competence center for additive manufacturing is operated under the IRPD brand.

« We want to make our customers even more successful »

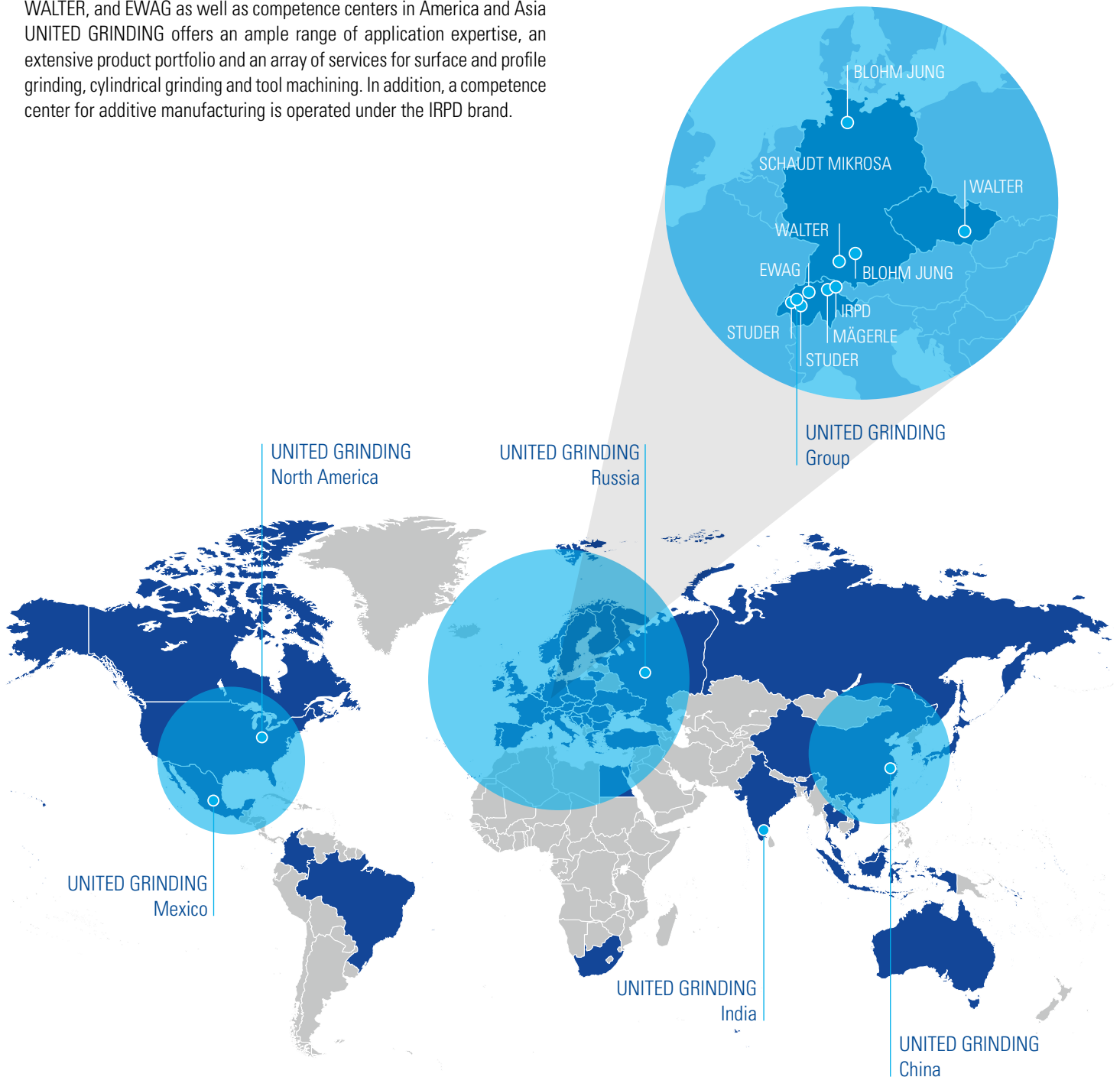



Walter Maschinenbau GmbH
Jopestr. 5 · 72072 Tübingen, Germany
Tel. +49 7071 9393-0
info@walter-machines.com

For worldwide contact details, please visit
walter-machines.com

